

Protecting

Our

Water

Sources

AquClean[®]

Oil/Water Separators

SEPARATORS THAT WORK!

HOW A 10 PPM SEPARATOR WORKS:

To get 10PPM you must remove essentially all of the particles 20 microns and larger.

How do you do this?

You need to use a Coalescer to capture these very small oil particles, so they do not get sucked out the discharge pipe!

How does a Coalescer do this?

The Coalescer is constructed using materials that attract oil and repel water. As the small oil particles come in contact with the Coalescer, they attach to it and wick their way to the top. Additionally, the particles collide with each other and get bigger causing them to rise much quicker.

Where Should The Coalescer Be Located?

The Coalescer should be as close to the outlet end of the separator as possible and as far away from any parallel plates as possible. This will limit the Coalescer to capturing the minimum amount of oil needed to get the desired effluent rating.

If The Coalescer is too close to the parallel plates, it will get clogged and become a flow restricter or get ripped out of it's frame, creating a maintenance problem!

The AquaClean™ Coalescer is a "One-Piece" unit that can be removed from grade without the need of:

1. Dismantling
2. De-watering
3. Confined space entry

This can save hundreds or thousands of dollars per event.

This feature combined with the parallel plates being at the front of the units is a "Major Plus" in analyzing the ease of maintenance and future maintenance costs.

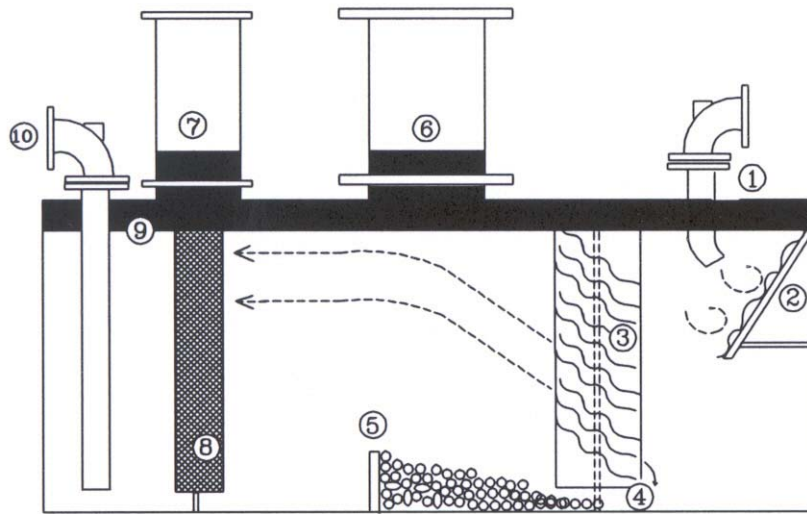

10 PPM Separator Design Features

1. Inlet and Outlet adapters are 150" R.F. Flanges with 2" vent fittings. Inlet and Outlet are on the top centerline of tank as per Underwriters Laboratories requirements for underground fuel storage vessels.
2. The flow of oily water is directed against an angled corrugated plate to assist in the development of laminar flow through the vessel. Plate also assists in oil coalescence.
3. The flow of the oily water is directed through a series of corrugated parallel plates that are positioned on a 40-45° incline. This incline is greater than the angle of repose of oily/gritty sludges. The plates are self-cleaning due to the angle. The heavy sludges and oily encapsulated grits will fall back out towards the front of the unit and make their way under the plate pack.
4. The opening under the plate pack allows heavy sludges to move forward to the sludge baffle for easy "at-grade" cleaning.
5. The sludge baffle is located beneath a manway for easy sludge removal.
6. The 24" I.D. access manway allows for easy access to the unit for cleaning and inspection.
7. Rectangular Manway houses single piece coalescer and provides for easy "at grade" removal.
8. One-piece coalescer consisting of a monofilament oleophilic medium matrix. The coalescer attracts the small micron oil particles that may not have agglomerated with the larger particles making their way rapidly to the top of the unit. The small particles become large particles and wick their way to the top for removal.
9. Oil accumulates in the top of the vessel out of the flow path of the water. Vessels can accumulate up to 40% of their volume as oil before effluent quality is compromised.
10. Clean water is drawn off the bottom of the outlet end of the separator. As a gallon of oily water enters the opposite end, a gallon of clean water is discharged.
11. Separators 1500 gallons and smaller are only equipped with one (1) 30" diameter manway for access to the coalescer and internal components. (see drawings for details)

STANDARD OIL WATER SEPARATOR EQUIPMENT

1. 150 lb. R.F. FLANGE
2. LAMINAR FLOW PLATE
3. SLUDGE BAFFLE
4. SEDIMENT CHAMBER
5. STRIKER PLATE
6. COALESCING PLATE PACK
7. REMOVABLE PLATES
8. 4" OUTLET PIPE
9. 2"Ø VENT FITTING
10. 2"Ø LEVEL MONITOR FITTING
11. 4" NPT FOR OIL PUMP OUT ACCESS
12. 30"Ø MANWAY FOR SEPARATOR AND PLATE PACK ACCESS
13. LIFTING LUG
14. REMOVABLE COALESCER PACK
15. 3/4" FOPLG FOR ELECTRICAL PASS-THRU

EXTERIOR COATING:
BRUSHBLASTED TO S.S.P.C. ND. 6
MATERIAL: PLASTEEL FRP 100 MILS.
INTERIOR COATING:
OPTIONAL

10 PPM
SINGLE-WALL
OIL/WATER
SEPARATOR

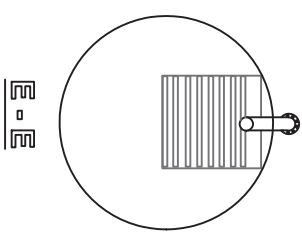
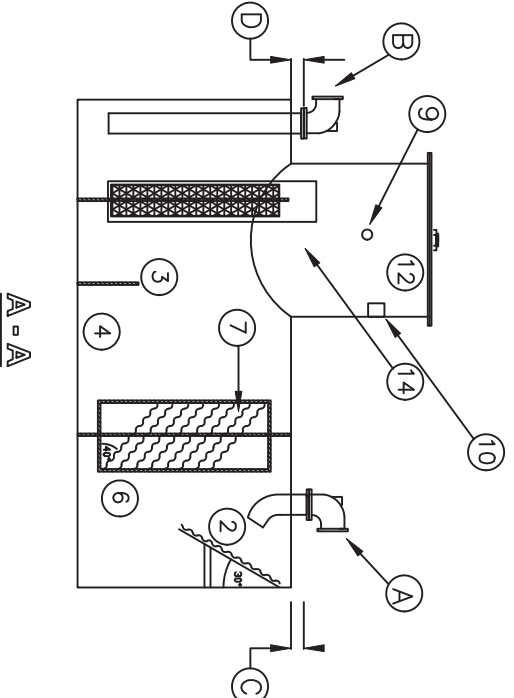
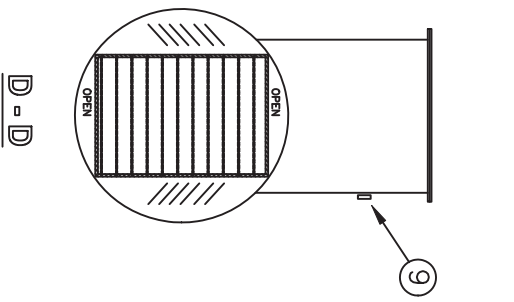
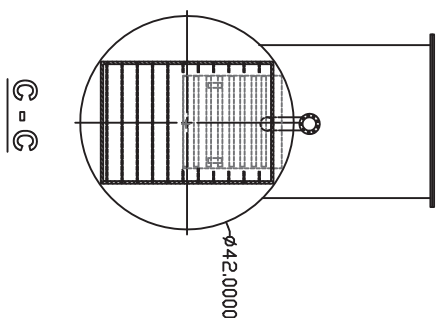
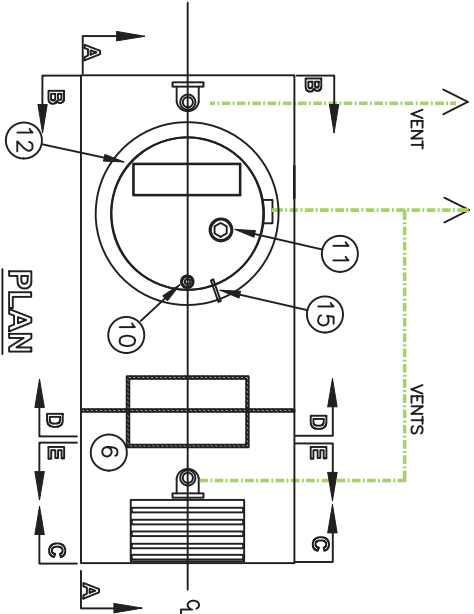
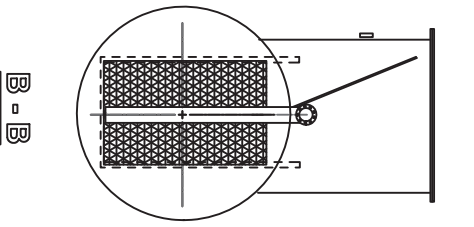

MODEL NO.	FLOW RATE	OIL STORAGE	SPILL CAPACITY	DIAMETER	LENGTH	STEEL THICKNESS	A I.D.	B I.D.	C Height	D Height	Weight Lbs.
429610-65	65	220	300	3'-6"	8'-0"	7GA.	4"	4"	8"	4"	1200
5012010-150	150	400	750	4'-2"	10'-0"	7GA.	6"	6"	8"	4"	1800

METAL
PRODUCTS, CO.

ALL RIGHTS RESERVED. THIS DRAWING OR ANY PART THEREOF MUST NOT BE REPRODUCED IN ANY FORM WITHOUT WRITTEN PERMISSION OF METAL PRODUCTS COMPANY, INC.

DWG NO:	1E-10
SCALE:	NONE
SHEET:	1
DATE:	8/4/99

NOTE: Inlets, outlets and manways must be vented.

Failure to vent outlet can result in the syphoning of the unit.

EXTERIOR COATING:
BRUSHBLASTED TO S.S.P.C. NO. 6
MATERIAL: PLASTEEL
THICKNESS: 100 MILS - SHELL
100 MILS - HEADS
INTERIOR COATING:
OPTIONAL

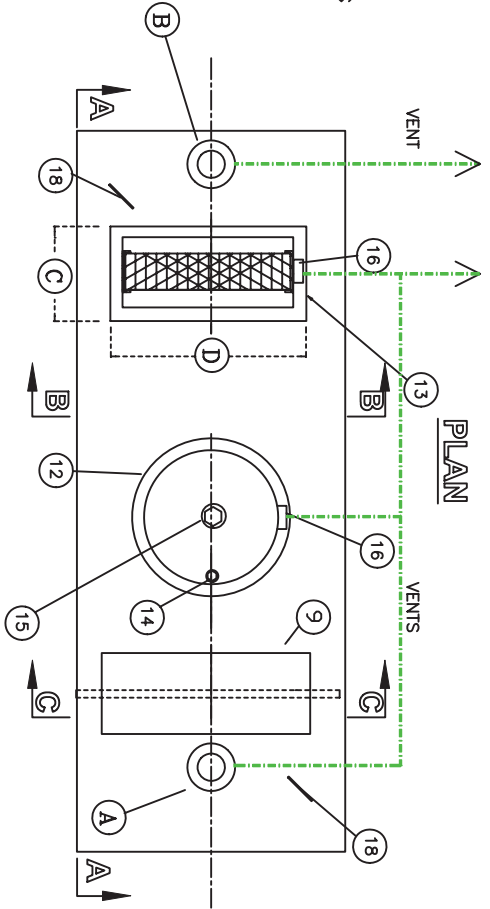

- STANDARD OIL WATER SEPARATOR EQUIPMENT**
1. 150 lb. R.F. FLANGE
 2. FLOW DIRECTOR
 3. LAMINAR FLOW ENHANCER PLATE
 4. SLUDGE COLLECTION
 5. SEDIMENT CHAMBER
 6. UNDERFLOW BAFFLE
 7. SLUDGE BAFFLE
 8. STRIKER PLATES
 9. CORRUGATED PLATES
 10. DIL / WATER SEPARATOR CHAMBER
 11. OUTLET DOWNCOMER
 12. 24"ø MANWAY W/ BOLT-ON EXTENSION FOR SEPARATOR ACCESS
 13. RECTANGULAR MANWAY & EXTENSION FOR 'AT GRADE' COALESCER REMOVAL
 14. 2"ø NPT COUPLING FOR SENSOR CONNECTION
 15. 4" NPT FOR DIL PUMP OUT ACCESS
 16. 2" NPT FITTING
 17. SECONDARY COALESCER WITH RETRIEVAL HANDLE
 18. LIFTING LUG

DRAWING TITLE
**10 PPM
SINGLE-WALL
OIL/WATER
SEPARATOR**

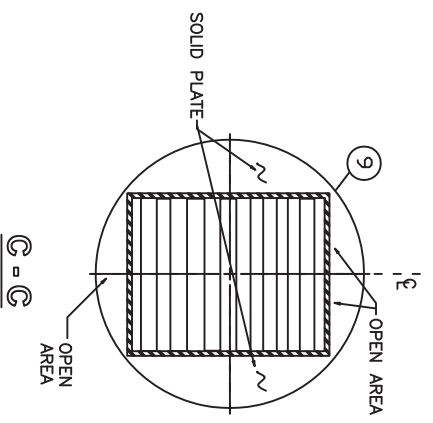
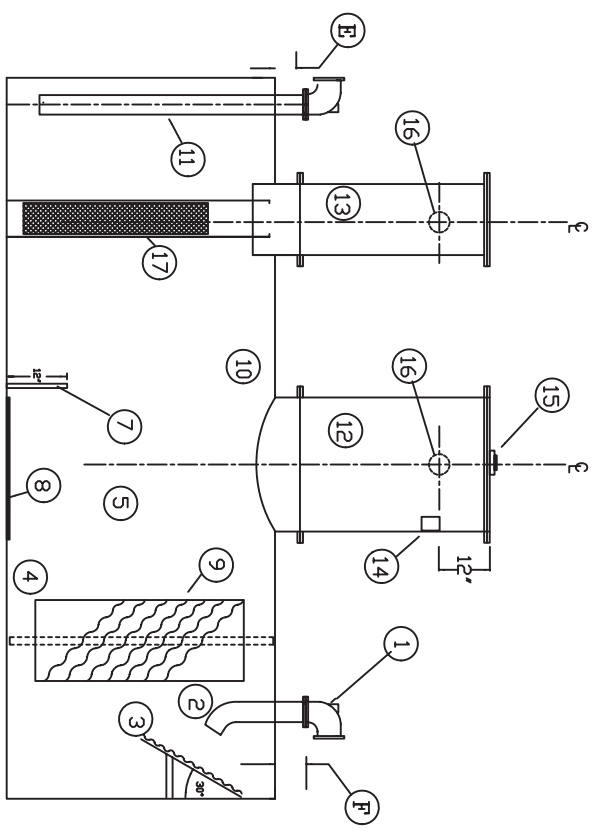
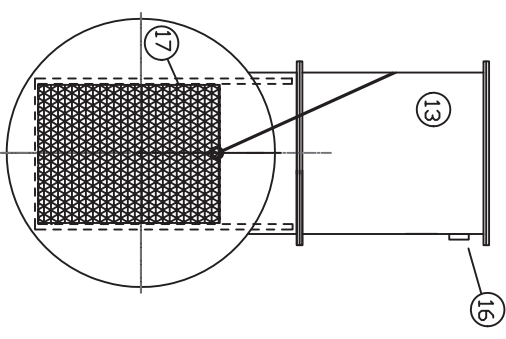

AquaClean

MODEL NO.	FLOW RATE	OIL STORAGE CAPACITY	SPLILL CAPACITY	DIAMETER	LENGTH	STEEL THICKNESS	A I.D.	B I.D.	C Inches	D Inches	E Height	F Height	Weight Lbs.
10-2000	200	800	1500	5'-4"	12'-0"	7/8"	6"	6"	20"	46"	4"	8"	4200
10-3000	300	1200	2200	5'-4"	18'-0"	7/8"	6"	6"	20"	46"	4"	8"	4950
10-4000	400	1600	2800	5'-4"	24'-0"	7/8"	6"	6"	20"	46"	4"	8"	5810
10-5000	600	2000	3500	6'-0"	23'-10"	1/4"	8"	8"	20"	56"	4"	10"	8090
10-6000	850	2400	4200	6'-0"	28'-8"	1/4"	8"	8"	20"	56"	4"	10"	9025
10-7000	950	2800	4900	7'-0"	24'-4"	1/4"	8"	8"	20"	60"	4"	10"	9205
10-8000	1000	3200	5600	7'-0"	28'-0"	1/4"	8"	8"	20"	60"	4"	10"	10495
10-9000	1150	3600	6300	8'-0"	24'-4"	1/4"	8"	8"	20"	62"	4"	10"	11005
10-10000	1350	4000	7500	8'-0"	26'-8"	1/4"	8"	8"	20"	62"	4"	10"	12225
10-12000	1650	4800	8500	8'-0"	32'-0"	1/4"	10"	10"	20"	65"	4"	10"	13600
10-15000	1950	6000	11000	10'-0"	25'-6"	5/16"	12"	12"	20"	90"	4"	12"	16420
10-20000	2500	8000	15000	10'-0"	34'-0"	5/16"	12"	12"	20"	90"	4"	12"	21800
10-25000	3000	10000	18000	10'-6"	38'-9"	3/8"	14"	14"	20"	96"	4"	14"	29710
10-30000	4000	12000	20000	10'-6"	46'-6"	3/8"	16"	16"	20"	96"	4"	14"	33795

DWG NO: HF-10
SCALE: NONE
SHEET: 1

ALL RIGHTS RESERVED. THIS DRAWING OR ANY PART THEREOF SHALL NOT BE REPRODUCED IN ANY FORM WITHOUT WRITTEN PERMISSION OF METAL FABRICATOR COMPANY, INC.

DNM BY: JAS
DATE: 7/27/99

NOTE: Inlets, outlets and mainways must be vented.

Failure to vent outlet can result in the siphoning of the unit.

SEPARATORS THAT WORK!

TEST SHOW:

To Get 15PPM You Must Remove Essentially All Of The Particles 60 Microns And Larger.

How Much Retention Time Does This Take?

You Need To Raise An Oil Particle At Least 1 Foot So It Does Not Get Sucked Out The Discharge Pipe!

SO:

Stokes' Law States: $V_r = g(P_w - P_o) \times (D \times D) / 18u$

Where:

V_r	=	Rate of Rise of a Particle
g	=	Acceleration caused by Gravity (981 cm/sec)
P_w	=	Specific Gravity of Water
P_o	=	Specific Gravity of Oil
D	=	Diameter of Oil Particle
u	=	Viscosity of Water at 40 degrees F.

Assume: .90 for Specific Gravity of Oil and 1.0 for Water.
(60 Micron Particle of Oil is .006 cm)

Then: $V_r = 981 \times (1 - .90) \times (.006 \times .006) / (18 \times .0153) = .013 \text{ cm/sec}$
 $.013 / 2.54 = .005 \text{ in/sec} \times 60 \text{ sec} / 12 \text{ in} = .0256 \text{ feet/min}$

Amount of Time to Raise a 60 Micron Particle 1 foot is: $1 / .0256 = \underline{39 \text{ minutes}^*}$

*This is without plates

A considerable portion of separation and coalescence occurs on the corrugated entrance plate of the AquaClean™ separator. Also, the parallel plate pack causes the particles to rise 4+ times faster.

If you double the diameter of an oil particle, it will rise 4x times faster!

What Does This Mean?

If your plates are not at the furthest point towards the inlet, you cannot get 10 minute throughputs!

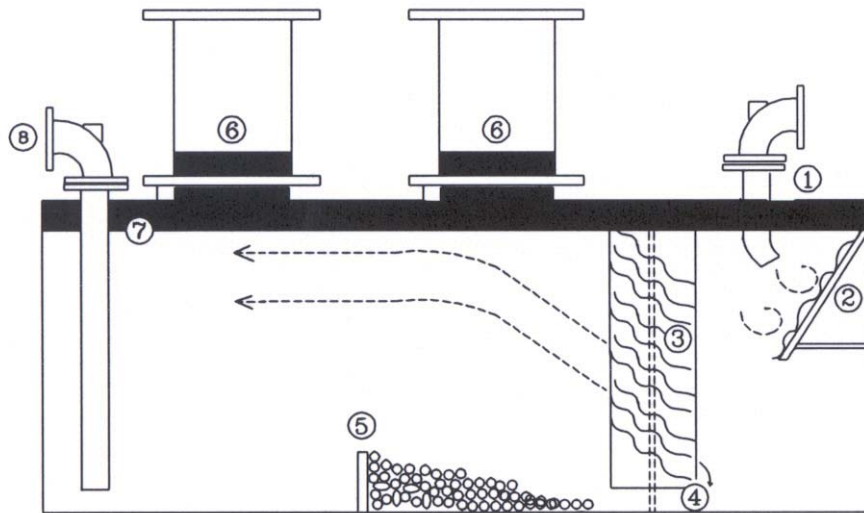

15 PPM Separator Design Features

1. Inlet and Outlet adapters are 150" F.F. Flanges with 2" vent fittings. Inlet and Outlet are on the top centerline of tank as per Underwriters Laboratories requirements for underground fuel storage vessels.
2. The flow of oily water is directed against an angled corrugated plate to assist in the development of laminar flow through the vessel. Plate also assists in oil coalescence.
3. The flow of the oily water is directed through a series of corrugated parallel plates that are positioned on a 40-45° incline. This incline is greater than the angle of repose of oily/gritty sludges. The plates are self-cleaning due to the angle. The heavy sludges and oily encapsulated grits will fall back out towards the front of the unit and make their way under the plate pack.
4. The opening under the plate pack allows heavy sludges to move forward to the sludge baffle for easy "at-grade" cleaning.
5. The sludge baffle is located beneath a manway for easy sludge removal.
6. The access manways allow for easy access to the unit and also provide additional oil storage capacity. Under excessive flow, the manways allow the accumulated oil to rise with the liquid level, preventing explosion.
7. Oil accumulates in the top of the vessel out of the flow path of the water. Vessels can accumulate up to 40% of their volume as oil before effluent quality is compromised.
8. Clean water is drawn off the bottom of the outlet end of the separator. As a gallon of oily water enters the opposite end, a gallon of clean water is discharged.
9. Separators 1500 gallons and smaller are only equipped with one (1) 24" I.D. access manway for internal access and cleaning.

AquClean[®]

Oil/Water Separators

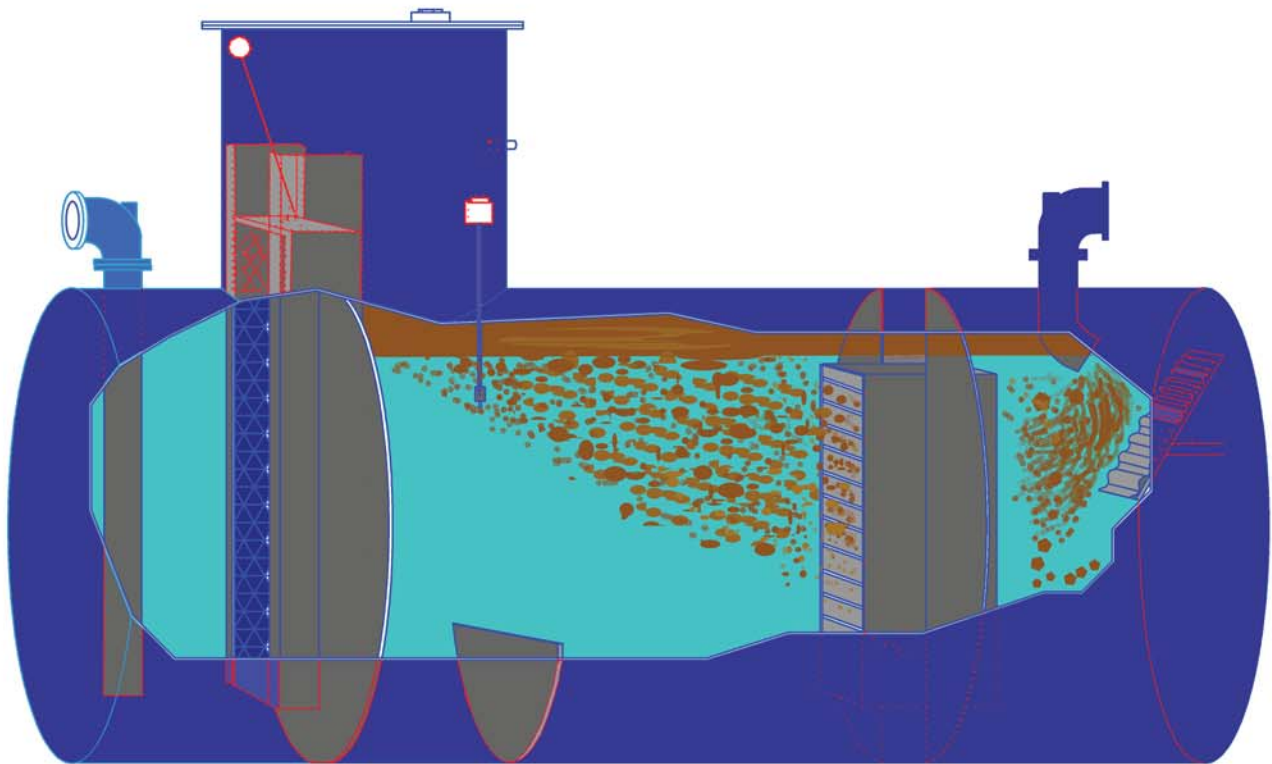

Separators that work!

Metal Products Company * 800.424.7373